

CSATM

21001 - Wexford II



- Standard 10.3 oz. Cartridge
- Mechanical Advantage 7:1
- Retractable Seal Puncturing Device
- Injection Mold, Nylon-Fiberglass
- Hex Drive Rod
- Built-in Ladder Hook
- Steel Catch Plate
- D-I-Y and Professional Model



41001 - Wexford



41001-R



- Standard 10.3 oz. Cartridge
- Mechanical Advantage 7:1
- Wear Compensating Device
- Retractable Seal Puncturing Device
- Corrosion Resistant Epoxy Finish
- Hex Drive Rod
- Built-in Ladder Hook
- Steel Catch Plate
- D-I-Y, Professional and Industrial Model
- Reinforced Front End Version Available - Model 41001-R



41004 - Chilton

UPGRADED



- Standard 10.3 oz. Cartridge
- Mechanical Advantage 12:1
- Switchable Flow Control
- Seal Puncture Device
- Wear Compensating Device
- Built-in Ladder Hook
- High Volume Usage
- Catch Plate - Sintered Steel
- Barrel Turns - Application Around Corners
- Low-Medium Viscosity Materials
- Thumb Activated Instant Pressure Release
- All Component Replaceable Parts
- Available Without Switchable Flow Control - Model 41004-M/1



41004-XT - Chilton Extra Thrust

UPGRADED



- Standard 10.3 oz. Cartridge
- Mechanical Advantage 18:1
- Switchable Flow Control
- Seal Puncture Device
- Wear Compensating Device
- Built-in Ladder Hook
- Catch Plate - Sintered Steel
- Barrel Turns - Application Around Corners
- Medium-High Viscosity Materials
- Thumb Activated Instant Pressure Release
- Professional, Industrial and Auto After-Market Use
- All Component Replaceable Parts
- Available Without Switchable Flow Control - Model 41004-XTM/1



41004-2T - Ascot



- Standard 10.3 oz. Cartridge
- Mechanical Advantage 26:1
- Wear Compensating Device
- Support Straps - Secure Cartridge Fit
- Built-in Ladder Hook
- Catch Plate - Sintered Steel
- Barrel Turns - Application Around Corners
- High Viscosity Materials
- Thumb Activated Instant Pressure Release
- Professional, Industrial and Auto After-Market Use
- All Component Replaceable Parts



41007 - Selby



- 6 oz. Semco® & Semkit® Cartridge Systems
- Bayonet Lock on Retainer
- Mechanical Advantage 12:1
- Switchable Flow Control
- Wear Compensating Device
- Built-in Ladder Hook
- Catch Plate - Sintered Steel
- Thumb Activated Instant Pressure Release
- All Component Replaceable Parts



63001 - Bexley
61001 - Tyne



Series 3

Series 2



- Standard 10.3 oz. Cartridge
- Series 3 Air System – Model 63001
- Series 2 Air System – Model 61001
- Air Action on Cartridge Plunger
- Drawn Aluminum Barrel
- True Adjustable Air Regulator – 75 PSI Maximum Output
- 145 PSI Maximum Input
- Instant Dump Valve
- Silencer
- Quick Release End Cap
- All Component Replaceable Parts
- Rotating Air Hose Connector Included

63004-LP - Whitley
61004-LP - Tamar



Series 3

Series 2



- Standard 10.3 oz. Cartridge and 10 oz. Sausage
- Series 3 Air System – Model 63004-LP
- Series 2 Air System – Model 61004-LP
- Pre-Configured for Cartridge Application
- Plunger Included for Sausage Application
- Piston Rod Action on Cartridge Plunger or Sausage
- Plunger Extension - Reduces Waste
- Drawn Aluminum Barrel
- Instant Dump Valve
- Silencer
- Quick Release End Cap
- True Adjustable Air Regulator – 100 PSI Maximum Output
- 145 PSI Maximum Input
- All Component Replaceable Parts
- Rotating Air Hose Connector and Six White Cone Nozzles Included

63004-HP - Whitley HP



Series 3

Series 1



- 10 oz. Cartridge/Sausage Version – Model 63004-300HP
Pre-Configured for Cartridge Application – Sausage Plunger Included
- 20 oz. Sausage Version – Model 63004-600HP
Pre-Configured for Sausage Application – Cartridge Plunger Included
- Series 1 Air System Also Available
- High Power - 484 lbs. Nominal Thrust
- Plunger Extension - Reduces Waste
- Drawn Aluminum Barrel
- Instant Dump Valve
- Silencer
- Quick Release End Cap
- True Adjustable Air Regulator – 100 PSI Maximum Output
- 145 PSI Maximum Input
- All Component Replaceable Parts
- Rotating Air Hose Connector and Six White Cone Nozzles Included

82010-L - Volten 300 Light



- Standard 10.3 oz. Cartridge
- Powered by 12 Volt Lithium Ion Battery Pack
- Maximum Force 475 lbs.
- Variable Speed Control
- One-Hour Fast Charge
- All Component Replaceable Parts
- Battery Charger and One Battery Included
- Battery Part #82001-L
- Charger Part #82002-L

83010 - Bradford 300



- Standard 10.3 oz. Cartridge
- Powered by 18V Lithium Battery Pack
- Maximum Force 787 lbs.
- Variable Speed Control
- 30 Minute Fast Charge
- All Component Replaceable Parts
- Battery Charger and One Battery Included
- Battery Part #83001
- Charger Part #83002

COX
Single Component

10 oz. Cartridge

COX™ Single Component 29 oz. Cartridge

41002 - Jumbo Quart



- Standard 29 oz. Cartridge
- Mechanical Advantage 12:1
- Switchable Flow Control
- Seal Puncture Device
- Wear Compensating Device
- Built-in Ladder Hook
- Catch Plate – Sintered Steel
- Barrel Turns – Application Around Corners
- Low-Medium Viscosity Materials
- Thumb Activated Instant Pressure Release
- High Volume Usage
- All Component Replaceable Parts
- Available With 18:1 Mechanical Advantage – Model 41002-XT
- Available with 26:1 Mechanical Advantage – Model 41002-2T
- Available Without Switchable Flow Control – Model 41002-M/1



63002 - Berkshire
61002 - Jumbo Air



- Standard 29 oz. Cartridge
- Series 3 Air System – Model 63002
- Series 2 Air System – Model 61002
- Drawn Aluminum Barrel
- Instant Dump Valve
- Silencer
- Piston Rod Action on Cartridge Plunger
- True Adjustable Air Regulator - 100 PSI Maximum Output
- 145 PSI Maximum Input
- Front Plate Flips Up for Cartridge Installation
- All Component Replaceable Parts
- Rotating Air Hose Connector Included



63002-UP - Berkshire Upright
61002-UP - Jumbo Air Upright



- Standard 29 oz. Cartridge
- Series 3 Air System – Model 63002-UP
- Series 2 Air System – Model 61002-UP
- 45" Long with Joist Guide Attached
- Reduces Bending and Reaching
- Front Plate Flips Up for Cartridge Installation
- Drawn Aluminum Barrel
- Instant Dump Valve
- Silencer
- Piston Rod Action on Cartridge Plunger
- True Adjustable Air Regulator - 100 PSI Maximum Output
- 145 PSI Maximum Input
- All Component Replaceable Parts
- Rotating Air Hose Connector Included



82029-L - Volten Quart Light



- Standard 29 oz. Cartridge
- Powered by 12 Volt Lithium Ion Battery Pack
- Maximum Force 475 lbs.
- Variable Speed Control
- One-Hour Fast Charge
- All Component Replaceable Parts
- Battery Charger and One Battery Included
- Battery Part #82001-L
- Charger Part #82002-L



83029 - Bradford Quart



- Standard 29 oz. Cartridge
- Powered by 18V Lithium Battery Pack
- Maximum Force 787 lbs.
- Variable Speed Control
- 30 Minute Fast Charge
- All Component Replaceable Parts
- Battery Charger and One Battery Included
- Battery Part #83001
- Charger Part #83002



51000 – Avon 300



- Standard 10 oz. Sausage and 10.3 oz. Cartridge
- Pre-Configured for Sausage Application
- Plunger Included for Cartridge Application
- Mechanical Advantage 12:1
- Switchable Flow Control
- Plunger Extension – Reduces Waste
- Wear Compensating Device
- Drawn Aluminum Barrel
- Interchangeable Pull Handle
- Quick Release End Cap
- All Component Replaceable Parts
- Includes Six White Cone Nozzles, Spare Sausage Plunger, Ladder Hook and Spanner Wrench
- Available with Clear Plastic Barrel – Model 51000-C
- Available with Hook Rod – Model 51000-H
- Available with Clear Plastic Barrel and Hook Rod – Model 51000-CH
- Available with 18:1 Mechanical Advantage – All Variants
- 400 ml. Version Available - Model 51000-400
- Available Without Switchable Flow Control – Model 51000-M



31001-600 – Prescott 600



- 10 oz. / 20 oz. Sausage and 10.3 oz. Cartridge
- Pre-Configured for Sausage Application
- Plungers Included for Cartridge
- Mechanical Advantage 10:1
- Plastic Barrel & Handle – Lightweight and Ergonomic
- Built-In Ladder Hook
- Quick Release End Cap
- Includes Six White Cone Nozzles
- All Component Replaceable Parts



51001 – Avon 600



- 10 oz. / 20 oz. Sausage, 10.3 oz. Cartridge and Bulk Application
- Pre-Configured for Sausage Application
- Plungers Included for Cartridge and Bulk (G2) Applications
- Mechanical Advantage 12:1
- Switchable Flow Control
- Plunger Extension – Reduces Waste
- Wear Compensating Device
- Drawn Aluminum Barrel
- Interchangeable Pull Handle
- Quick Release End Cap
- All Component Replaceable Parts
- Includes Six Yellow Cone Nozzles, Ladder Hook and Spanner Wrench
- Available with Clear Plastic Barrel – Model 51001-C
- Available with Hook Rod – Model 51001-H
- Available with Clear Plastic Barrel and Hook Rod – Model 51001-CH
- Available with 18:1 Mechanical Advantage – All Variants (add XT to end of model number)
- Available Without Switchable Flow Control – Model 51001-M



51001-2T – Ascot 600



- 10 oz. / 20 oz. Sausage, 10.3 oz. Cartridge and Bulk Application
- Pre-configured for Sausage Application
- Plungers Included for Cartridge and Bulk (G2) Applications (Bulk on 20 oz. Only)
- Mechanical Advantage 26:1
- Plunger Extension – Reduces Waste
- Drawn Aluminum Barrel
- Interchangeable Pull Handle
- Quick Release End Cap
- All Component Replaceable Parts
- Includes Six Yellow Cone Nozzles, Ladder Hook and Spanner Wrench
- 10 oz. Version Available – Model 51000-2T



51001-1000M – Avon 1000M



- 34 oz. Sausage
- 3M® Cap Included for Loop Sealant Application
- Mechanical Advantage 12:1
- Switchable Flow Control
- Plunger Extension – Reduces Waste
- Wear Compensation Device
- Drawn Aluminum Barrel
- Interchangeable Pull Handle
- All Component Replaceable Parts



COXTM

Single Component

Sausage / Bulk



63003 - Carlisle

- 10 oz. Sausage, 20 oz. Sausage and 10.3 oz. Cartridge
- Pre-Configured for Sausage Application
- Rod & Plunger included for Cartridge Application
- Floating Plunger Action with Interchangeable System from Sausage to Cartridge
- Plunger Extension - Reduces Waste
- Drawn Aluminum Barrel
- Instant Dump Valve
- Silencer
- Quick Release End Cap
- True Adjustable Air Regulator - 100 PSI Maximum Output
- 145 Maximum Input
- All Component Replaceable Parts
- Air Hose Connector and Six White Cone Nozzles Included



63006 - Fenwick 61006 - Trent



- 10 oz. Sausage Version - Model 63006-300
- 20 oz. Sausage Version - Model 63006-600
- 400 ml. Sausage Version - Model 63006-400
- Series 3 Air System - Model 63006
- Series 2 Air System Also Available
- Plunger Extension - Reduces Waste
- Drawn Aluminum Barrel
- Instant Dump Valve
- Floating Plunger Action with Secure Cord
- True Adjustable Air Regulator - 100 PSI Maximum Output (300/400ml.)
- 125 PSI Maximum Output (600ml.)
- 145 PSI Maximum Input
- Silencer
- Quick Release End Cap
- All Component Replaceable Parts
- Rotating Air Hose Connector and Six White Cone Nozzles Included
- Variants Available with Handle Positioned at Front (Model 63006-600/M) or Rear (Model 63006-600/M1) of Applicator
- High Pressure 600ml. Version Available - Model 63006-600HP



Series 3

Series 2



63006-600/F - Fenwick Spreader

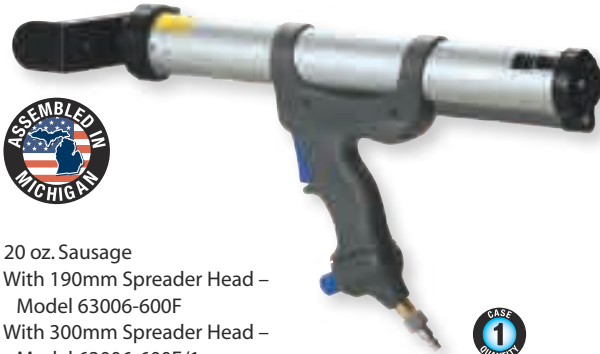

- 20 oz. Sausage
- With 190mm Spreader Head - Model 63006-600F
- With 300mm Spreader Head - Model 63006-600F/1
- With 400mm Spreader Head - Model 63006-600F/2
- Plunger Extension - Reduces Waste
- Drawn Aluminum Barrel
- Instant Dump Valve
- Floating Plunger Action with Secure Cord
- True Adjustable Air Regulator - 125 PSI Maximum Output
- 145 Maximum Input
- Silencer
- Quick Release End Cap
- All Component Replaceable Parts
- Rotating Air Hose Connector Included



61006-1000 - Wilton 1000



- 34 oz. Sausage
- 3M® Cap Included for Loop Sealant Application
- Floating Plunger Action with Secure Cord
- Plunger Extension – Reduces Waste
- Drawn Aluminum Barrel
- Instant Dump Valve
- Silencer
- Quick Release End Cap
- True Adjustable Air Regulator – 100 PSI Maximum Output
- 145 Maximum Input
- All Component Replaceable Parts



82600-L - Volten 600 Light



- 10 oz./20 oz. Sausage Packs
- Powered by 12 Volt Lithium Ion Battery Pack
- Maximum Force 475 lbs.
- Variable Speed Control
- One-Hour Fast Charge
- All Component Replaceable Parts
- Battery Charger and One Battery Included
- Includes Six White Cone Nozzles
- Battery Part #82001-L
- Charger Part #82002-L
- Clear Plastic Barrel Version Available – Model 82600-LC



83600 - Bradford 600

- 10 oz./20 oz. Sausage Packs
- Powered by 18V Lithium Battery Pack
- Maximum Force 787 lbs.
- Variable Speed Control
- 30 Minute Fast Charge
- All Component Replaceable Parts
- Battery Charger and One Battery Included
- Includes Six White Cone Nozzles
- Battery Part #83001
- Charger Part #83002
- Clear Plastic Barrel Version Available – Model 83600-C



41009 - Barnet

- 34 oz. Cartridge
- Mechanical Advantage 12:1
- Switchable Flow Control
- Wear Compensating Device
- Catch Plate – Sintered Steel
- Thumb Activated Instant Pressure Release
- All Component Replaceable Parts



COXTM
Single Component
Sausage / Cartridge



51002 - Portland

51002

51002/2SC

- 20 oz. Bulk Application – Model 51002-600
- 34 oz. Bulk Application – Model 51002-1000
- 56 oz. Bulk Application – Model 51002-1600
- All Sizes Available with Plastic 2-Start Cap:
 - 20 oz. Bulk Application – Model 51002-600/2SC
 - 27 oz. Bulk Application – Model 51002-800/2SC
 - 34 oz. Bulk Application – Model 51002-1000/2SC
 - 56 oz. Bulk Application – Model 51002-1600/2SC
- Leather Plunger Assembly
- Switchable Flow Control
- Mechanical Advantage 12:1
- Wear Compensating Device
- Drawn Aluminum Barrel
- Interchangeable Pull Handle
- Quarter Turn Steel End Cap or Quick Release Plastic Cap (depending on version)
- All Component Replaceable Parts
- Includes Six Yellow Cone Nozzles and Spanner Wrench
- Available with 18:1 Mechanical Advantage – All Variants (add XT to end of model number)
- Available Without Switchable Flow Control



51003-1400 - Preston

- 48 oz. Bulk Application
- 2.5" Drawn Aluminum Barrel
- Plastic (G2) Plunger Assembly
- Switchable Flow Control
- Mechanical Advantage 12:1
- Wear Compensating Device
- Interchangeable Pull Handle
- Quick Release End Cap
- All Component Replaceable Parts
- Includes Six Yellow Cone Nozzles, Plastic Ladder Hook and Spanner Wrench
- Available Without Switchable Flow Control



61009 - Bulk Air



- 24 oz. Bulk Application
- Drawn Aluminum Barrel
- Instant Dump Valve
- Quick Release End Cap
- Piston Rod Action on Bulk Material
- True Adjustable Air Regulator – 100 PSI Maximum Output
- 145 PSI Maximum Input
- Leather Plunger Assembly
- Reverse Air – Plunger Return with Trigger
- All Component Replaceable Parts
- Air Hose Connector and Six Yellow Cone Nozzles Included



63009-1400 - Oxford



- 48 oz. Bulk Application
- 2.5" Drawn Aluminum Barrel
- Plastic (G2) Plunger Assembly
- True Adjustable Air Regulator – 100 PSI Maximum Output
- 145 PSI Maximum Input
- Reverse Air – Plunger Return with Trigger
- Instant Dump Valve
- Silencer
- Quick Release End Cap
- All Component Replaceable Parts
- Air Hose Connector and Six Yellow Cone Nozzles Included



63007 - Ashford



- 10 oz. Sausage Version – Model 63007-300S
- 10 oz. Cartridge Version – Model 63007-300C
- 10 oz. Cartridge/Sausage Kit Version - Model 63007-300
- 20 oz. Sausage Version – Model 63007-600S
- Spray and Bead Application
- Dual Flow Controls Regulate Incoming Air Flow and Pattern of Spray
- Floating Plunger Action with Secure Cord
- True Adjustable Air Regulator – 100 PSI Maximum Output
- 145 PSI Maximum Input
- Silencer
- All Component Replaceable Parts
- 5 Outer Nozzles, 5 Inner Sausage Nozzles, 5 Inner Aluminum Cartridge Nozzles, 5 Inner Plastic Cartridge Nozzles and Air Hose Connector Included (inner nozzles included depends on variant)



82600-LB - Volten 600 Bulk Light



- 20 oz. Bulk
- Powered by 12 Volt Lithium Ion Battery Pack
- Maximum Force 475 lbs.
- Variable Speed Control
- One-Hour Fast Charge
- All Component Replaceable Parts
- Battery Charger and One Battery Included
- Includes Six Yellow Cone Nozzles
- Battery Part #82001-L
- Charger Part #82002-L
- Clear Plastic Barrel Version Available – Model 82600-BLC



83600-B - Bradford 600 Bulk



- 20 oz. Bulk
- Powered by 18V Lithium Battery Pack
- Maximum Force 787 lbs.
- Variable Speed Control
- 30 Minute Fast Charge
- All Component Replaceable Parts
- Battery Charger and One Battery Included
- Includes Six Yellow Cone Nozzles
- Battery Part #83001
- Charger Part #83002



41006 - Tuck Point



- 1 Quart Capacity Tube
- Mechanical Advantage 12:1
- Switchable Flow Control
- Wear Compensating Device
- Trowel or Pour Material into Tube for Dispensing
- Rubber Plunger Between Steel Plates
- Interchangeable Pull Handle
- Patented Catch Plate (Sintered Steel)
- Barrel Turns – Application Around Corners
- Thumb Activated Instant Pressure Release
- All Component Replaceable Parts
- Tuck Point Nozzle, Grout Nozzle, Tube and Turbine Mixer Included
- Available Without Switchable Flow Control – Model 41006-M



COXTM
Single Component
Bulk / Sausage / Cartridge

COX™ Dual Component 25 / 50 ml.

M25



- 25 ml. x 25 ml.
- Dedicated Mix Ratio 1:1
- Mechanical Advantage 11:1
- Easy Loading Breech – Secure Fit
- Full Cartridge Support



MP25



- 50 ml. Cartridge Systems
- Square Back Cartridges
- Multi-Ratio Conversions 1:1, 2:1, 4:1 & 10:1 (Must Specify)
- Full Kit Version Available
- Lightweight and Powerful
- Easy Loading Breech - Secure Fit
- Rigid Glass Reinforced Nylon Engineered Plastic



MR50 / MR25



- 50 ml. Cartridge Systems
- Individual Ratios or Full Kit Options are Available (must specify)
- Round Back Cartridges – MR50 Series
- Square Back Cartridges – MR25 Series
- Round & Square Back Cartridges (full kit) – Model MR50/25
- Also Accommodates 37/43 ml. 2:1 Systems
- 75ml. 1:1 Plunger Rack for Square and Round Back Also Available
- Lightweight - Molded From Glass Reinforced ABS
- Easy Loading Breech – Secure Fit



A25



- 25 ml. x 25 ml.
- Dedicated 1:1 Mix Ratio
- Available in 2:1 Mix Ratio for a 37/43 ml. System – Model A25/2
- Nominal Thrust 235 lbs.
- Easy Loading Breech
- True Adjustable Air Regulator – 75 PSI Maximum Output
- 145 PSI Maximum Input
- Instant Dump Valve
- All Component Replaceable Parts
- Air Hose Connector Included



A50



- 50 ml. Cartridge Systems
- Square Back Cartridge Systems
- Dedicated 1:1/2:1 or 4:1/10:1 Mix Ratios (Must Specify)
- Nominal Thrust 157 lbs.
- True Adjustable Air Regulator – 50 PSI Maximum Output
- 145 PSI Maximum Input
- Silencer
- Instant Dump Valve
- All Component Replaceable Parts
- Air Hose Connector Included
- Available for S-Style Cartridge Systems – Model A50S



M75



- 75 ml. x 75 ml.
- Stubby Cartridge System
- Mechanical Advantage 18:1
- Support Discs – Secure and Accurate Cartridge Fit
- Wear Compensating Device
- Catch Plate – Sintered Steel
- Low-Medium Viscosity Materials
- All Component Replaceable Parts



A75LP



- 75 ml. x 75 ml.
- Applicator for 75ml. Round Cartridge Systems Available – Model A75/1
- Nominal Thrust 484 lbs.
- True Adjustable Air Regulator – 100 PSI Maximum Output
- 145 PSI Maximum Input
- Instant Dump Valve
- Support Discs – Secure and Accurate Cartridge Fit
- All Component Replaceable Parts
- Air Hose Connector Included



M90



- 6 oz. Total System
- Dedicated 1:1 Mix Ratio
- Mechanical Advantage 18:1
- Support Strap – Secure Cartridge Fit
- Wear Compensating Device
- Catch Plate – Sintered Steel
- Low-High Viscosity Materials
- All Component Replaceable Parts



A90LP



- 6 oz. Total System
- Dedicated Mix Ratio 1:1
- Nominal Thrust 368 lbs.
- True Adjustable Air Regulator – 75 PSI Maximum Output
- 145 PSI Maximum Input
- Instant Dump Valve
- Support Strap – Secure Cartridge Fit
- All Component Replaceable Parts
- Air Hose Connector Included



M100



- Multi-Ratio Conversions:
 - 100 ml. x 100 ml. (Pre-configured Arrangement)
 - 100 ml. x 75 ml. (Kit Included)
- Mechanical Advantage 18:1
- Wear Compensating Device
- Low-Medium Viscosity Materials
- Support Strap – Secure Cartridge Fit
- Catch Plate – Sintered Steel
- All Component Replaceable Parts



A100LP



- 100 ml. x 100 ml.
- Dedicated 1:1 Mix Ratio
- Nominal Thrust 484 lbs.
- Support Strap – Secure and Accurate Cartridge Fit
- Instant Dump Valve
- True Adjustable Air Regulator – 100 PSI Maximum Output
- 145 PSI Maximum Input
- Reverse Air – Plunger Return with Trigger
- All Component Replaceable Parts
- Air Hose Connector Included



COX™

Dual Component

75 / 90 / 100 ml.

COX™ Dual Component 150 / 180 ml.



M150LV

- Multi-Ratio Conversions:
 - 150 ml. x 150 ml. (Pre-configured Arrangement)
 - 150 ml. x 75 ml. (Kit Available)
- Mechanical Advantage 12:1
- Support Strap – Secure Cartridge Fit
- Wear Compensating Device
- Catch Plate – Sintered Steel
- Low Viscosity Materials
- All Component Replaceable Parts



M150



- Multi-Ratio Conversions:
 - 150 ml. x 150 ml. (Pre-configured Arrangement)
 - 150 ml. x 75 ml. (Kit Included)
 - 150 ml. x 100 ml. (Kit Included)
- Mechanical Advantage 18:1
- Support Strap – Secure Cartridge Fit
- Wear Compensating Device
- Catch Plate – Sintered Steel
- Low-High Viscosity Materials
- All Component Replaceable Parts



M150XL

- Multi-Ratio Conversions:
 - 150 ml. x 150 ml. (Pre-configured Arrangement)
 - 150 ml. x 75 ml. (Kit Included)
- Mechanical Advantage 26:1
- Single Side Rails / Steel Plungers – Lighter Weight
- Support Strap - Secure Cartridge Fit
- Catch Plate – Sintered Steel
- Wear Compensating Device
- High Viscosity Materials
- All Component Replaceable Parts



A150LP



Series 1

Series 3



- Dedicated Mix Ratio (Must Specify)
 - 150 ml. x 150 ml. (1:1 Mix Ratio) – Model A150LP/1 (Series 3 Air System Available)
 - 150 ml. x 75 ml. (2:1 Mix Ratio) – Model A150LP/2
 - 150 ml. x 100 ml. – Model A150LP/3
- Multi-Ratio Version (Does Not Have Reverse Air) – Model A150LP
- Multi-Ratio (Series 3) Version with Quick Change Plungers Available – Model A150LPMR-S3
- Nominal Thrust 484 lbs.
- True Adjustable Air Regulator – 100 PSI Maximum Output
- 145 PSI Maximum Input
- Instant Dump Valve
- Support Strap – Secure Cartridge Fit
- Reverse Air – Plunger Return with Trigger
- All Component Replaceable Parts
- Air Hose Connector Included



M180

- 12 oz. Total System
- Dedicated 1:1 Mix Ratio
- Mechanical Advantage 18:1
- Support Straps – Secure Cartridge Fit
- Wear Compensating Device
- Catch Plate – Sintered Steel
- Low-High Viscosity Materials
- All Component Replaceable Parts
- Pneumatic Version Available – Model A180LP (Special Order)



M200



- 200 ml. x 200 ml.
- Dedicated 1:1 Mix Ratio
- Mechanical Advantage 18:1
- Wear Compensating Device
- Catch Plate – Sintered Steel
- Support Straps – Secure Cartridge Fit
- Low-High Viscosity Materials
- All Component Replaceable Parts



M200X



- 200 ml. x 200 ml.
- Dedicated 1:1 Mix Ratio
- Mechanical Advantage 26:1
- Catch Plate – Sintered Steel
- Support Straps – Secure Cartridge Fit
- Wear Compensating Device
- High Viscosity Materials
- All Component Replaceable Parts



A200LP



- 200 ml. x 200 ml.
- Dedicated 1:1 Mix Ratio
- Nominal Thrust 484 lbs.
- Support Straps – Secure and Accurate Cartridge Fit
- Instant Dump Valve
- True Adjustable Air Regulator – 100 PSI Maximum Output
- 145 PSI Maximum Input
- Reverse Air – Plunger Return with Trigger
- All Component Replaceable Parts
- Air Hose Connector Included



M200LVMR



- 200 ml. Total System
- Multi-Ratio 1:1, 2:1, 4:1 and 10:1 (Kits Included)
- Twist & Lock Plunger System – Quick & Easy Ratio Changes
- Mechanical Advantage 12:1
- Side Loading Frame – Accurate Cartridge Placement
- Support Strap – Secure Cartridge Fit
- Catch Plate – Sintered Steel
- Wear Compensating Device
- Low Viscosity Materials
- All Component Replaceable Parts



M200MR

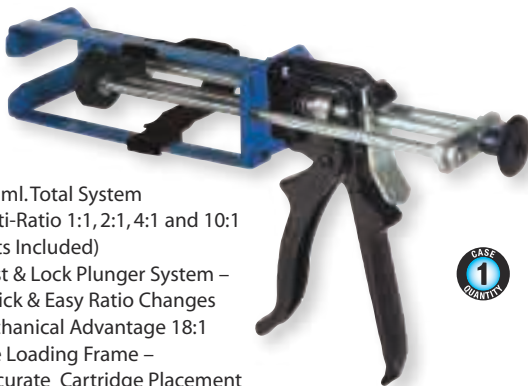

- 200 ml. Total System
- Multi-Ratio 1:1, 2:1, 4:1 and 10:1 (Kits Included)
- Twist & Lock Plunger System – Quick & Easy Ratio Changes
- Mechanical Advantage 18:1
- Side Loading Frame – Accurate Cartridge Placement
- Support Strap – Secure Cartridge Fit
- Catch Plate – Sintered Steel
- Wear Compensating Device
- Low Viscosity Materials
- All Component Replaceable Parts



M200XMR

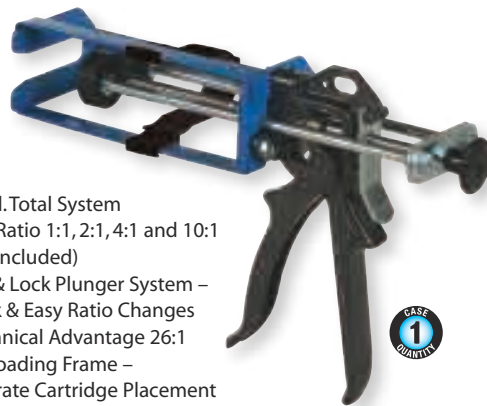

- 200 ml. Total System
- Multi-Ratio 1:1, 2:1, 4:1 and 10:1 (Kits Included)
- Twist & Lock Plunger System – Quick & Easy Ratio Changes
- Mechanical Advantage 26:1
- Side Loading Frame – Accurate Cartridge Placement
- Support Strap – Secure Cartridge Fit
- Catch Plate – Sintered Steel
- Wear Compensating Device
- High Viscosity Materials
- All Component Replaceable Parts



COXTM
Dual Component
200 ml.

A200LPMR



Series 1

- 200 ml. Total System
- Multi-Ratio 1:1, 2:1, 4:1 and 10:1 (Kits Included)
- Twist & Lock Plunger System – Quick & Easy Ratio Changes
- Series 3 Air System Also Available
- Nominal Thrust 484 lbs.
- True Adjustable Air Regulator – 100 PSI Maximum Output
- 145 PSI Maximum Input
- Instant Dump Valve
- Side Loading Frame – Accurate Cartridge Placement
- Support Strap – Secure Cartridge Fit
- Reverse Air – Plunger Return with Trigger
- All Component Replaceable Parts
- Air Hose Connector Included
- High Pressure Version Available – Model A200HPMR

Series 3



81200 **NEW**

- 200 ml. Total System
- Multi-Ratio 1:1, 2:1, 4:1 and 10:1 (Kits Included)
- Powered by 18V Lithium Battery Pack
- Maximum Force 787 lbs.
- Variable Speed Control
- 30 Minute Fast Charge
- All Component Replaceable Parts
- Battery Charger and One Battery Included
- Battery Part #83001
- Charger Part #83002



M265X

- 18 oz. Total System (265 ml. x 265 ml.)
- Dedicated 1:1 Mix Ratio
- Mechanical Advantage 26:1
- Catch Plate – Sintered Steel
- Support Strap – Secure Cartridge Fit
- Wear Compensating Device
- High Viscosity Materials
- All Component Replaceable Parts



M310

- Application of Dual 10 oz. Sausages or Cartridges (Must Specify)
- Mechanical Advantage 18:1
- Wear Compensating Device
- Patented Catch Plate (Sintered Steel)
- Low-High Viscosity Materials
- Includes Plastic Manifold Assembly
- All Component Replaceable Parts



A310HP



- Application of Dual 10 oz. Sausage or Cartridge (Must Specify)
- Nominal Thrust 1,188 lbs.
- True Adjustable Air Regulator – 100 PSI Maximum Output
- 145 PSI Maximum Input
- Instant Dump Valve
- Reverse Air – Plunger Return with Trigger
- All Component Replaceable Parts
- Air Hose Connector Included
- Includes Plastic Manifold Assembly



M330



- 300 ml. x 30 ml.
- Dedicated Mix Ratio 10:1
- Mechanical Advantage 18:1
- Support Straps – Secure Cartridge Fit
- Wear Compensating Device
- Catch Plate – Sintered Steel
- All Component Replaceable Parts



A330LP



- 300 ml. x 30 ml.
- Dedicated 10:1 Mix Ratio
- Nominal Thrust 484 lbs.
- Support Straps – Secure Cartridge Fit
- True Adjustable Air Regulator – 100 PSI Maximum Output
- 145 PSI Maximum Input
- Instant Dump Valve
- Reverse Air – Plunger Return with Trigger
- All Component Replaceable Parts
- Air Hose Connector Included
- Available for Side by Side 300ml. x 30ml. System – Model AP330LP
- 14.4 Volt Battery Version Available – Model 80330



M300LV



- Multi-Ratio Conversions:
 - 300 ml. x 150 ml. (Pre-configured Arrangement)
 - 300 ml. x 300 ml. (Kit Included)
 - 300 ml. x 100 ml. (Kit Available)
- Mechanical Advantage 12:1
- Support Discs – Secure and Accurate Cartridge Fit
- Catch Plate – Sintered Steel
- Wear Compensating Device
- Low Viscosity Materials
- All Component Replaceable Parts



M300



- Multi-Ratio Conversions:
 - 300 ml. x 300 ml. (Pre-configured Arrangement)
 - 300 ml. x 150 ml. (Kit Included)
 - 300 ml. x 100 ml. (Kit Available)
 - 300 ml. x 75 ml. (Kit Included)
 - 150 ml. x 150 ml. (Kit Available)
 - 150 ml. x 75 ml. (Kit Available)
- Mechanical Advantage 18:1
- Support Discs – Secure and Accurate Cartridge Fit
- Catch Plate – Sintered Steel
- Wear Compensating Device
- Low-High Viscosity Materials
- All Component Replaceable Parts



M300XL



- Multi-Ratio Conversions:
 - 300 ml. x 300 ml. (Pre-configured Arrangement)
 - 300 ml. x 150 ml. (Kit Included)
 - 300 ml. x 75 ml. (Kit Included)
 - 300 ml. x 100 ml. (Kit Available)
 - 150 ml. x 150 ml. (Kit Available)
 - 150 ml. x 75 ml. (Kit Available)
- Mechanical Advantage 26:1
- Single Side Rails / Steel Plungers – Lighter Weight
- Support Discs – Secure and Accurate Cartridge Fit
- Catch Plate – Sintered Steel
- Wear Compensating Device
- High Viscosity Materials
- All Component Replaceable Parts



M300X



- Multi-Ratio Conversions:
 - 300 ml. x 300 ml. (Pre-configured Arrangement)
 - 300 ml. x 150 ml. (Kit Included)
 - 300 ml. x 100 ml. (Gun Available) Model M300X/3
 - 300 ml. x 75 ml. (Kit Available)
- Mechanical Advantage 26:1
- Support Discs – Secure and Accurate Cartridge Fit
- Double Side Rails – Added Durability
- Catch Plate – Sintered Steel
- Wear Compensating Device
- High Viscosity Materials
- All Component Replaceable Parts



COX™

Dual Component

300 / 330 ml.



- Dedicated Mix Ratio (Must Specify)
 - 300 ml. x 300 ml. (1:1 Mix Ratio) – Model A300LP/1 (Series 3 Air System Available)
 - 300 ml. x 150 ml. (2:1 Mix Ratio) – Model A300LP/2
 - 300 ml. x 100 ml. (3:1 Mix Ratio – Does Not Have Reverse Air) – Model A300LP3
 - 300 ml. x 75 ml. (4:1 Mix Ratio) – Model A300LP/4
- Multi-Ratio Version (Does Not Have Reverse Air) Model A300LP
- Nominal Thrust 484 lbs.
- True Adjustable Air Regulator – 100 PSI Maximum Output
- 145 PSI Maximum Input
- Support Discs – Secure and Accurate Cartridge Fit
- Instant Dump Valve
- Reverse Air – Plunger Return with Trigger
- All Component Replaceable Parts
- Air Hose Connector Included



- Multi-Ratio Conversions:
 - 300 ml. x 300 ml. (Pre-configured Arrangement)
 - 300 ml. x 150 ml. (Kit Included) (Series 3 Air System Available)
 - 300 ml. x 75 ml. (Kit Included)
- Multi-Ratio (Series 3) Version with Quick Change Plungers Available – Model A300HPMR-S3
- Nominal Thrust 1,188 lbs.
- True Adjustable Air Regulator – 100 PSI Maximum Output
- 145 PSI Maximum Input
- Support Discs – Secure and Accurate Cartridge Fit
- Instant Dump Valve
- Reverse Air – Plunger Return with Trigger
- All Component Replaceable Parts
- Air Hose Connector Included



- 300 ml. x 300 ml.
- Dedicated 1:1 Mix Ratio
- Powered by 18V Lithium Battery Pack
- Dual Drive Rack Mechanism
- Maximum Force 1,349 lbs.
- Variable Speed Control
- Dosing Available
- 30 Minute Fast Charge
- All Component Replaceable Parts
- Battery Charger and One Battery Included
- Battery Part #83001
- Charger Part #83002



- Co-Axial Cartridge Systems
- Available in Mix Ratios 1:1, 2:1, 4:1 and 10:1 (Must Specify)
- Mechanical Advantage 18:1
- Wear Compensating Device
- Catch Plate – Sintered Steel
- All Component Replaceable Parts
- Mechanical Advantage 26:1 Variant Available – Model M380X (Special Order)



- Co-Axial Cartridge Systems
- Available in Mix Ratios of 1:1, 2:1, 4:1 and 10:1 (Must Specify)
- Series 3 Air System Available in 10:1 Mix Ratio
- Instant Dump Valve
- Nominal Thrust 1,188 lbs.
- True Adjustable Air Regulator – 100 PSI Maximum Output
- 145 PSI Maximum Input
- Reverse Air – Plunger Return with Trigger
- All Component Replaceable Parts
- Air Hose Connector Included
- 18V Cordless Variant Available – Model 81380



- 200 ml. and 400 ml. Total Systems
- Available in Mix Ratios of 1:1, 2:1, 4:1 and 10:1 (Must Specify)
- Full Kit Version Available
- Mechanical Advantage 26:1
- Side Loading Frame – Accurate Cartridge Placement
- Catch Plate – Sintered Steel
- Wear Compensating Device
- High Viscosity Materials
- All Component Replaceable Parts
- 18:1 Mechanical Advantage Version Available – Model M400MR



Dual Component

400 / 600 ml.

A400LPMR

Series 1



Series 3



- 200 ml. and 400 ml. Total Systems
- Available in Mix Ratios of 1:1, 2:1, 4:1 and 10:1 (Must Specify)
- Series 3 Air System Available in all Variants
- Full Kit Version - Model A400LPMR
- Nominal Thrust 484 lbs.
- Side Loading Frame – Accurate Cartridge Placement
- Instant Dump Valve
- True Adjustable Air Regulator – 100 PSI Maximum Output
- 145 PSI Maximum Input
- Reverse Air – Plunger Return with Trigger
- All Component Replaceable Parts
- Air Hose Connector Included
- High Pressure Version Available - Model A400HPMR (Series 3 Air System Also Available)

81400 NEW



- 400 ml. Total System
- Multi Ratio 1:1, 2:1, 4:1 and 10:1 (Kits Included)
- Powered by 18V Lithium Battery Pack
- Maximum Force 787 lbs.
- Variable Speed Control
- 30 Minute Fast Charge
- All Component Replaceable Parts
- Battery Charger and One Battery Included
- Battery Part #83001
- Charger Part #83002

M600X



- 600 ml. x 600 ml. (Dedicated 1:1 Mix Ratio) Model M600X/1
- 600 ml. x 300 ml. (Dedicated 2:1 Mix Ratio) Model M600X/2
- 600 ml. x 150 ml. (Dedicated 4:1 Mix Ratio) Model M600X/4
- 600 ml. x 75 ml. (Dedicated 8:1 Mix Ratio) Model M600X/8
- Mechanical Advantage 26:1
- Catch Plate – Sintered Steel
- Support Discs – Secure and Accurate Cartridge Fit
- Wear Compensating Device
- High Viscosity Materials
- All Component Replaceable Parts

A600HP

Series 1



Series 3

- 600 ml. x 300 ml. (Dedicated 2:1 Mix Ratio) Model A600HP/2 (Series 3 Air System Available)
- 600 ml. x 600 ml. (Dedicated 1:1 Mix Ratio) Model A600HP/1
- 600 ml. x 150 ml. (Dedicated 4:1 Mix Ratio) Model A600HP/4
- Multi-Ratio (Series 3) Version with Quick Change Plungers Available – Model A750HPMR-S3
- Nominal Thrust 1,188 lbs.
- Instant Dump Valve
- Support Discs – Secure and Accurate Cartridge Fit
- Reverse Air – Plunger Return with Trigger
- True Adjustable Air Regulator – 100 PSI Maximum Output
- 145 PSI Maximum Input
- Air Hose Connector Included
- All Component Replaceable Parts
- 18V Dual Drive Version Available – Model 81600/2-D

A600HPS



- Application of Dual 20 oz. Sausage Packs
- Nominal Thrust 1,188 lbs.
- True Adjustable Air Regulator – 100 PSI Maximum Output
- 145 PSI Maximum Input
- Instant Dump Valve
- Reverse Air – Plunger Return with Trigger
- Air Hose Connector Included
- All Component Replaceable Parts
- Includes Manifold Assembly
- Static Mixers Available

COX™ Dual Component 750 ml.

M750X/1



- 750 ml. x 750 ml.
- Dedicated 1:1 Mix Ratio
750 ml. x 300 ml. (Gun Available)
– Model M750X/2
- Multi Ratio (Gun Available) –
Model M750X/kit
- Mechanical Advantage 26:1
- Wear Compensating Device
- High Viscosity Materials
- Catch Plate – Sintered Steel
- Support Discs – Secure and Accurate Cartridge Fit
- All Component Replaceable Parts



M750X/10



- 750 ml. x 75 ml.
- Multi-Ratio Version Available –
Model M750XMR
- Dedicated 10:1 Mix Ratio
- Mechanical Advantage 26:1
- Wear Compensating Device
- High Viscosity Materials
- Catch Plate – Sintered Steel
- Support Discs – Secure and Accurate Cartridge Fit
- All Component Replaceable Parts



A750HP/1



Series 3

Series 1



- 750 ml. x 750 ml. (1:1 Mix Ratio - Preconfigured Arrangement)
(Series 3 Air System Available)
- 750 ml. x 300 ml. (2:1 Mix Ratio) Model A750HP/2 (Kit Available)
- 750 ml. x 150 ml. (5:1 Mix Ratio) Model A750HP/5 (Kit Available)
- 750 ml. x 75 ml. (10:1 Mix Ratio) Model A750HP/10 (Series 3)
- Multi-Ratio (Series 3) Version with Quick Change Plungers
Available – Model A750HPMR-S3
- Nominal Thrust 1,188 lbs.
- True Adjustable Air Regulator – 100 PSI Maximum Output
- 145 PSI Maximum Input
- Instant Dump Valve
- Support Discs – Secure and Accurate Cartridge Fit
- Reverse Air – Plunger Return with Trigger
- Air Hose Connector Included
- All Component Replaceable Parts

A750HP/10



Series 3

Series 1



- 750 ml. x 75 ml.
- Dedicated 10:1 Mix Ratio (Series 3 Air System Available)
- 750 ml. x 750 ml. (1:1 Mix Ratio)
Model A750HP/1 (Series 3 Air System Available)
- 750 ml. x 300 ml. (2:1 Mix Ratio) Model A750HP/2
- 750 ml. x 150 ml. (5:1 Mix Ratio) Model A750HP/5
- Nominal Thrust 1,188 lbs.
- True Adjustable Air Regulator – 100 PSI Maximum Output
- 145 PSI Maximum Input
- Instant Dump Valve
- Support Discs – Secure and Accurate Cartridge Fit
- Reverse Air – Plunger Return with Trigger
- Air Hose Connector Included
- All Component Replaceable Parts

81750/1-D NEW



- 750 ml. x 750 ml.
- Dedicated 1:1 Mix Ratio
- Powered by 18V Lithium Battery Pack
- Dual Drive Rack Mechanism
- Maximum Force 1,349 lbs.
- Variable Speed Control
- Dosing Available
- 30 Minute Fast Charge
- All Component Replaceable Parts
- Battery Charger and One Battery Included
- Battery Part #83001
- Charger Part #83002



81750/10 NEW



- 750 ml. x 75 ml.
- Dedicated 10:1 Mix Ratio
- Powered by 18V Lithium
Battery Pack
- Maximum Force 787 lbs.
- Variable Speed Control
- 30 Minute Fast Charge
- All Component Replaceable Parts
- Battery Charger and One Battery Included
- Battery Part #83001
- Charger Part #83002
- 18V Dual Drive Version Available – Model 81750/10-D





Accessories



Grey Plastic Nozzle
2N1001



White Plastic Nozzle
1/4"
2N1002



Blue Plastic Nozzle
3/8"
2N1003



Red Plastic Nozzle
1/2"
2N1004



Black Plastic Nozzle
injection
2N1005



Yellow Cone
Plastic Nozzle
2N1006



Black Cone
Plastic Nozzle
2N1050



White Cone
Plastic Nozzle
2N1007



Steel Nozzle
3/8"
7N1001



Steel Nozzle
1/2"
7N1002



Steel Nozzle
3/4"
7N1003



Static Mixer (For A600HPS Only)
3475-16 - 16 Element
3475-20 - 20 Element
3475-23 - 23 Element

Static Mixer Extension
3475-EXT



Plastic Nozzle Holder
2N1201



Steel Nozzle Holder
7C1026



Black Tuck Point Nozzle
2N1030



Grey Grout Nozzle
2N1042



4" Clamp with Nylon Pads (shown)
71004-P

6" Clamp with Metal Pads
71006-M

6" Clamp with Nylon Pads
71006-P



7XS053 - 190mm 2" Spreader Attachment
7XS054 - 300mm 2" Spreader Attachment
7XS055 - 400mm 2" Spreader Attachment

O'Ring
2S2008
(sold separately)



Easi-Clamps
72003



Power-Clamps
72004



Ultra-Clamps
72005



Support Handle
7XS041



Inverter
AC-003

Air Assist Spray
Attachment
60020
With Pressure
Gauge
60021



2XP012 - 12V Carry Case
(Single Component Only)
2XP013 - 18V Carry Case
(Single Component Only)



7F1015 - 2 Gallon Follower Plate
7F1016 - 5 Gallon Follower Plate
7F1022 - 2.5" 2 Gallon Follower Plate
7F1023 - 2.5" 5 Gallon Follower Plate



Caulk Warmer
AC-001



Junior Caulk Warmer
AC-002

12V Charger
82002-L



18V Battery
83001



18V Charger
83002



12V Battery
82001-L



Turbine Mixer
3M1201



Aluminum Pull Handle/Hook
7H1001

Sulzer Mixpac USA Inc. in Haslett, Michigan is the exclusive U.S. distributor of COX hand-held sealant and adhesive applicators. All products in the COX line are manufactured in-house at three locations: Newbury, England; West London, England; and Haslett, Michigan.

Sulzer Mixpac USA's distribution center in Michigan offers a wide range of in-stock products with on time delivery commitments, customer and technical service, and a parts and repair service center. Our sales team works to create and maintain a partnership with our customers, listening to their views and ideas to ensure that future development remains focused on providing a range of products optimally suited to their changing needs.

By combining innovative design with excellent manufacturing standards, rigid quality management, a competitive pricing policy and an in-depth understanding of the sealant and adhesive worldwide market, we have developed a range of manual, pneumatic and battery operated applicators to satisfy application needs from the do-it-yourself to the industrial to the most sophisticated specialist markets.

Quality of output is carefully monitored by a quality assurance system, stringently applied to incoming materials and components, in-house manufacturing and the finished product. It is the key to the company's reputation for producing consistently high quality products at attractive prices, and is the reason that the COX brand is considered number one in the world for sealant applicators.

Warranty

Sulzer Mixpac USA Inc. offers a one-year limited warranty from the date of purchase against defects in materials and workmanship on all COX branded products. Sulzer will repair or replace the product at our option, at no cost to the purchaser for labor, parts or return transportation, if it is delivered to us or your local COX dealer.

Parts/Service

In the event COX products fail to meet the warranty criteria, Sulzer Mixpac USA Inc. will submit a quotation to the purchaser on costs for parts and labor. A full parts and service department is located on-site to provide continued technical assistance and support.

Schematics

Due to our commitment of producing the highest quality products on the market, we are continuously making up-grades and improvements on our tools. In order to supply the most up-to-date schematics, they are available on-line at our website, www.cox-applicators.com.

SULZER

Sulzer Mixpac USA Inc.

8181 Coleman Road • Haslett, Michigan 48840 USA
(800) 822-8114 • (517) 339-3330 • FAX (517) 339-3806
www.cox-applicators.com

© Sulzer Mixpac USA Inc.



Use the QR reader on your
smartphone to go directly to
www.cox-applicators.com/catalog